

# Precision No-Gap Broadband Fiber VOA

(all fiber types, build-in position sensor, high setting precision, no drift, bidirectional)

(US patent 8,666,218 and other patents pending)



DATASHEET

[Return to the Webpage](#)



## Features

- 0.2dB Low Loss
- 0.1dB Repeatable
- 300-2100 Broadband
- 65dB Attenuation
- SM, PM, MM, 106 $\mu$ m
- 1W Optical Power
- Linear Response

## Applications

- Sensor
- Channel Balance
- Instrumentation

The High Precision Series Variable Optical Attenuator (PVOA) offers exceptional performance with an ultra-low insertion loss of 0.2 dB and a wide operational range from 300 to 2100 nm. It features a continuous light path with no gaps, ultra-high setting stability of 0.1 dB, and a linear response that is independent of input optical power. Built on an innovative micro-electro-mechanical system (MEMS) platform with a fast piezo actuator, integrated laser, and optical position sensor, the PVOA delivers precise and stable attenuation controlled by an electrical signal, maintaining accuracy despite environmental variations. Unlike typical feedback control VOAs, it does not tap signal light that increases loss and maintains precision even at low optical power levels, ensuring uninterrupted light transmission thanks. This makes it ideal for interferometric sensors, ultra-high-speed data transmissions up to 200 Gb/s, and applications requiring extensive wavelength coverage. It is compatible with fibers having a 125-micron outer diameter, with other diameters available upon request. The PVOA can be precisely controlled up to 30 dB, with attenuation levels reaching up to 65 dB when precision is not required. The PVOA is also available as a component with four fiber ports: two for the VOA, one for laser light input, and one for connection to a detector. The laser and detector pair form a feedback control loop to precisely manage attenuation.

## Specifications

Parameter	Min	Typical	Max	Unit
Operation Wavelength	300		2500	nm
Insertion Loss <sup>[1]</sup>	0.1	0.2	0.5	dB
Polarization Dependent Loss		0.1	0.3	dB
Wavelength Dependence Loss		0.01	0.1	dB
Attenuation Accuracy/Repeatability 0.5-30dB		0.1	0.2	dB
Attenuation Setting Repeatability			0.1	dB
Extinction Ratio (PM version only)	19	25	28	dB
Attenuation	0	50	60	dB
Polarization Mode Dispersion (SM version only)		0.01	0.05	ps
Return Loss <sup>[2]</sup>		55		dB
Response Time		5	50	ms
Power Consumption			4	W
Optical Power handling <sup>[3]</sup>		600		mW
Operating Temperature	-5		75	°C
Storage Temperature	-40		85	°C
Package		40x25x10		mm

### Note:

- [1]. Without connector and at room temperature. For fiber core > 8mm, smaller fiber core loss is higher
- [2]. For SM fiber
- [3]. For fiber with core size > 8 mm. For small core see the curve at the end

Rev 01/08/26

+1 781-935-1200

sales@agiltron.com

www.agiltron.com

# Precision No-Gap Broadband Fiber VOA

(all fiber types, build-in position sensor, high setting precision, no drift, bidirectional)

(US patent 8,666,218 and other patents pending)



DATASHEET

## Mechanical Footprint Dimensions (with Driver) (Unit: mm)

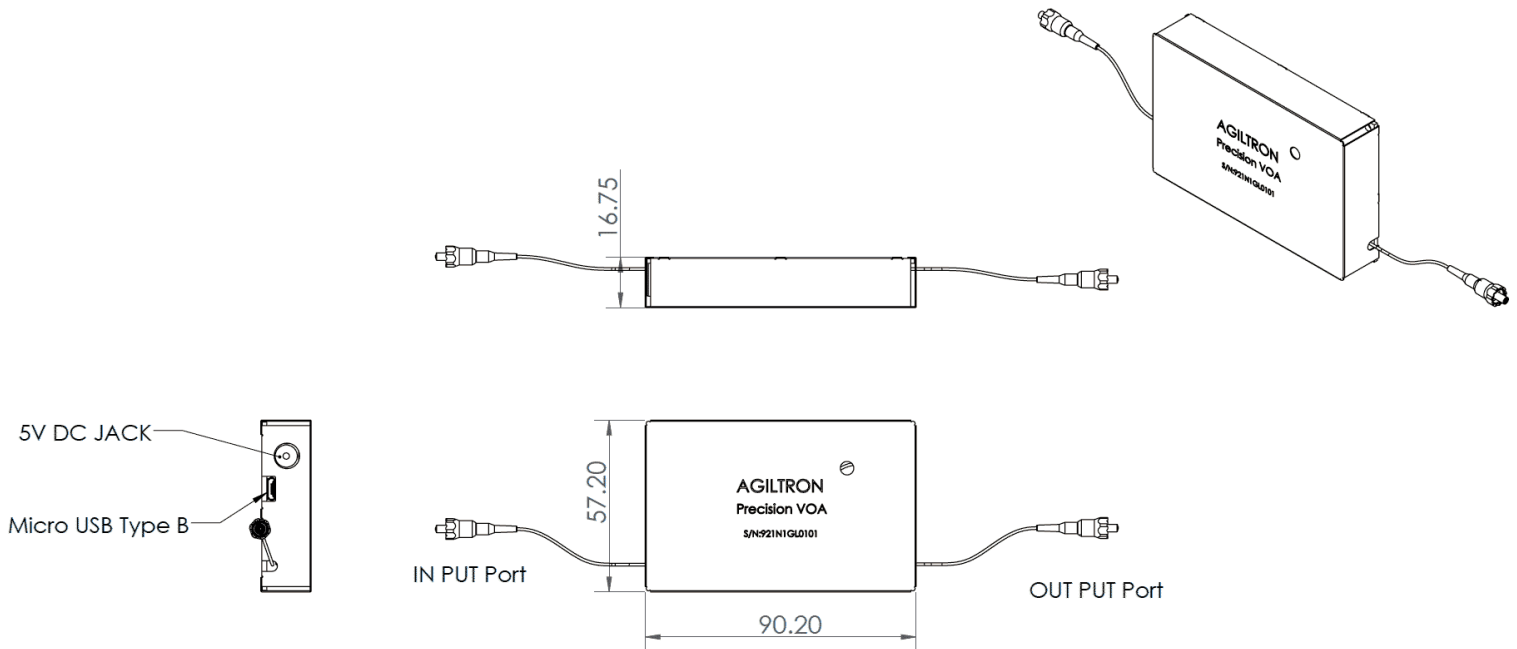

\*Product dimensions may change without notice. This is sometimes required for non-standard specifications.

## Electrical Control Interface

The VOA (Variable Optical Attenuator) can be controlled through either USB or RS232 interfaces:

- A 5V power supply from Agiltron must be connected to the device via a connector on the board.
- **USB Control:** Use a USB Type A to Micro USB Type B cable to control the device. The VOA accepts UART commands and is recognized as a serial device by the PC.
- **RS232 Control:** Use an RS232 to Micro USB Type B cable to control the device.

# Precision No-Gap Broadband Fiber VOA

(all fiber types, build-in position sensor, high setting precision, no drift, bidirectional)

(US patent 8,666,218 and other patents pending)



DATASHEET

## Mechanical Footprint Dimensions For Component (Unit: mm)

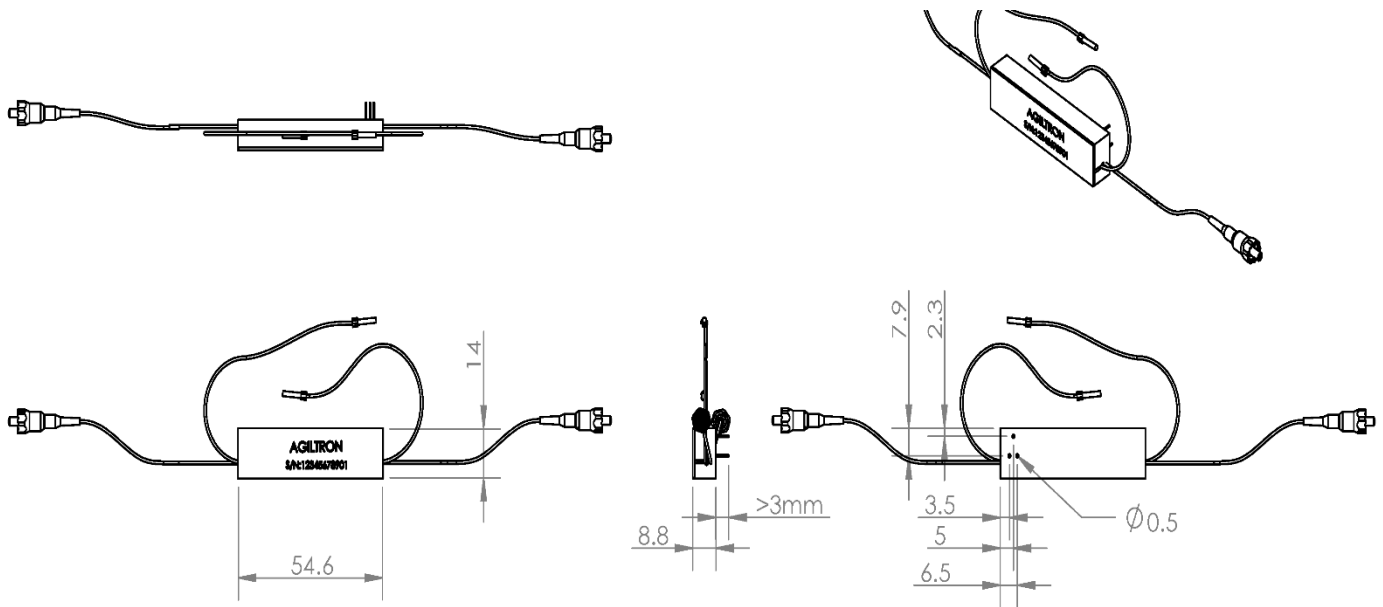

\*Product dimensions may change without notice. This is sometimes required for non-standard specifications.

## Electrical Control Interface

- + Pin
- - Pin
- Applying a voltage <60V

## Operation Instruction

- Avoid touching the bare PCB by hand, as this can damage the semiconductor chips due to electrostatic discharge. This is an OEM version intended for professional use. We offer a benchtop unit with metal casing and electrical grounding protection for general use.
- Connect the included power supply to the power source on the unit.
- Use the provided cable to connect the unit to a computer.
- Launch the supplied GUI software.
- Establish a connection with the unit via the GUI.
- Operate the unit using the GUI

# Precision No-Gap Broadband Fiber VOA

(all fiber types, build-in position sensor, high setting precision, no drift, bidirectional)

(US patent 8,666,218 and other patents pending)



## DATASHEET

### Ordering Information (Part Number)

Prefix	Type	Controller	Optical Power	Test Wavelength	Fiber Type	Fiber Cover	Fiber Length	Connector [1][2]
<b>PVOA-</b>	Piezo = 2 Special = 0	USB = 1 Component = C RS232 = 2 Special = 0	Regular = 1	350 = U 488 = 4 532 = 5 630 = 6 780 = 7 850 = 8 980 = 9 1060 = 1 1310 = 3 1550 = C 2000 = 2	<i>Pick from below table</i>	Bare fiber = 1 900um tube = 3 Special = 0	0.25m = 1 0.5m = 2 1.0m = 3 Special = 0	None = 1 FC/PC = 2 FC/APC = 3 SC/PC = 4 SC/APC = 5 ST/PC = 6 LC/PC = 7 Special = 0

[1]. Regular fiber connector has PER ~22dB. Connector with PER >27 dB is available using special process

[2]. The connector cannot be installed directly onto bare fiber, as it is prone to damage during shipping. However, the connector can be assembled on bare fiber if a 3 cm protective loose tube is added for reinforcement. The customer can remove this protective tube after testing. The optical power handling of a standard connector is less than 0.5 W for SM28 fiber and decreases further with smaller core fibers.

**Note:**

- PM1550 fiber works well for 1310nm

### Fiber Type Selection Table:

01	<b>SMF-28</b>	34	<b>PM1550</b>	67	<b>OM1 (MMF 62.5/125µm)</b>
02	<b>SMF-28e</b>	35	<b>PM1950</b>	68	<b>OM2 (MMF 50/125µm)</b>
03	<b>Corning XB</b>	36	<b>PM1310</b>	69	<b>OM3 (MMF 50/125µm)</b>
04	<b>SM450</b>	37	<b>PM400</b>	70	<b>OM4 (MMF 50/125µm)</b>
05	<b>SM1950</b>	38	<b>PM480</b>	71	<b>GIF50 (GIF 50/125µm)</b>
06	<b>SM600</b>	39	<b>PM630</b>	72	<b>GIF625 (GIF 62.5/125µm)</b>
07	<b>Hi780</b>	40	<b>PM850</b>	73	<b>105/125µm</b>
08	<b>SM800</b>	41	<b>PM980</b>	74	<b>FG105LCA</b>
09	<b>Hi980</b>	42	<b>PM780</b>	75	<b>FG50LGA</b>
10	<b>Hi1060</b>	43	<b>PM350</b>	76	<b>FG10LDA</b>
11	<b>SM300</b>	44	<b>PM405</b>	77	
12	<b>SM400</b>	45	<b>PM460</b>	78	
13		46		79	

\*Product dimensions may change without notice. This is sometimes required for non-standard specifications.

# Precision No-Gap Broadband Fiber VOA

(all fiber types, build-in position sensor, high setting precision, no drift, bidirectional)

(US patent 8,666,218 and other patents pending)



## DATASHEET

### Optical Power Handling vs Wavelength for Standard SM Fibers

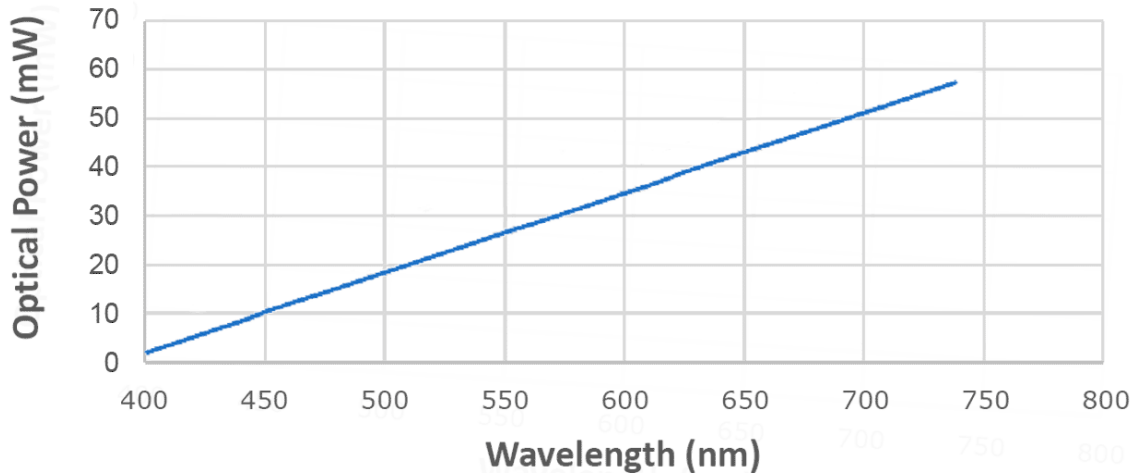

### Typical Insertion Loss vs Wavelength (1240-1630nm)

#### 1x2 MEMS Switch

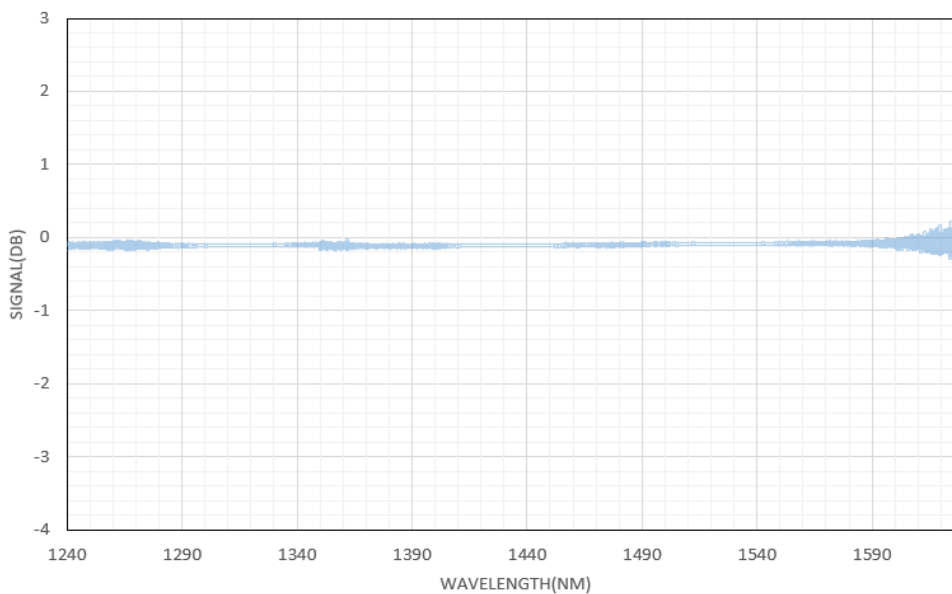

# Precision No-Gap Broadband Fiber VOA

(all fiber types, build-in position sensor, high setting precision, no drift, bidirectional)

(US patent 8,666,218 and other patents pending)



## DATASHEET

### Typical Wavelength Dependence @20dB Attenuation

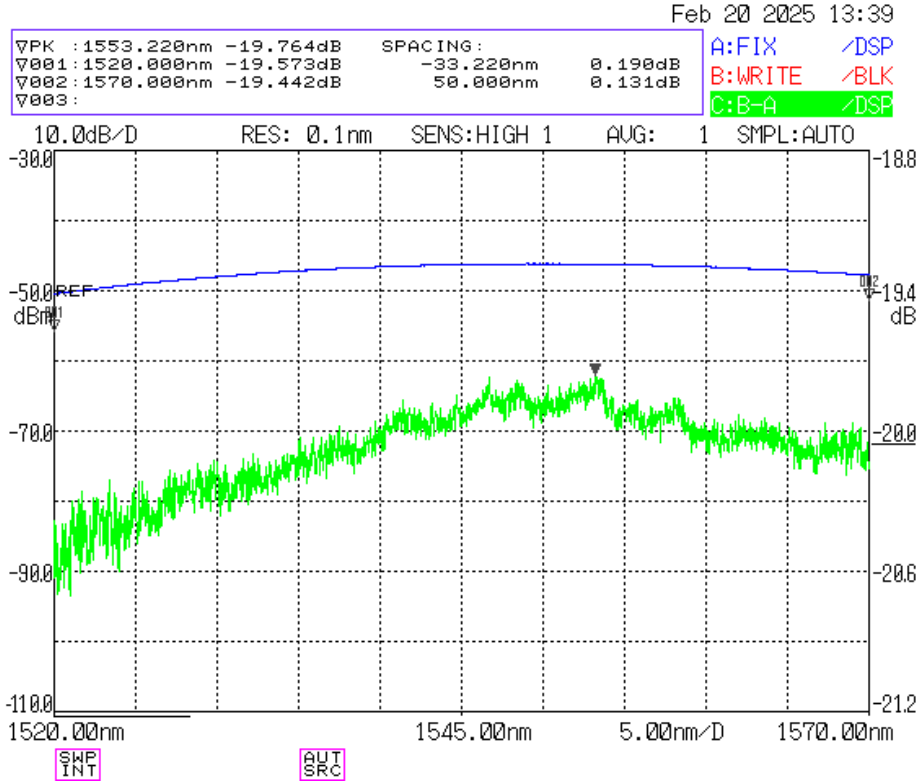

# Precision No-Gap Broadband Fiber VOA

(all fiber types, build-in position sensor, high setting precision, no drift, bidirectional)

(US patent 8,666,218 and other patents pending)



DATASHEET

## GUI

